

# MC556-Mini

## Functional characteristics

- Voltage input range: DC20V~50V
- Max. peak current: 5.6A
- Subdivision range: 400~25600ppr
- Pulse form: Pulse + direction
- Pulse response frequency: 0~200KHz
- Motor parameter self-regulation
- Provided with overvoltage, overcurrent and tracking error and out-of-tolerance protection functions, etc.

## Operating environment and parameters

- Storage temperature: -20°C~65°C
- Operating temperature: 0°C~50°C
- Operating humidity: 40~90%RH (without condensation)
- Vibration frequency: < 0.5G (4.9m/s<sup>2</sup>), 10~60 Hz (non-continuous operation).
- Places with dust, oil stain, corrosive gases, high humidity and vibration should be avoided. Combustible gases and conductive dust should be prohibited

**Main applications:** Suitable for automatic equipment and instruments in various motion control fields such as electronic processing and detection, semiconductor packaging, laser cutting and welding, laser phototypesetting, packaging machinery, engraving machines, markers, cutters, apparel plotters, medium-sized CNC machine tools and automatic assembly equipment.



## Product Introduction

MC556 is a digital two-phase hybrid step motor drive designed based on the latest 32-bit DSP control technology. It can help to customize any subdivision within 400~25600 and any current within the rated range and has an additional automatic motor parameter identification function for adopting corresponding running parameters for different motors and making motors run very smoothly with an extremely low noise.

## Schematic diagram of product

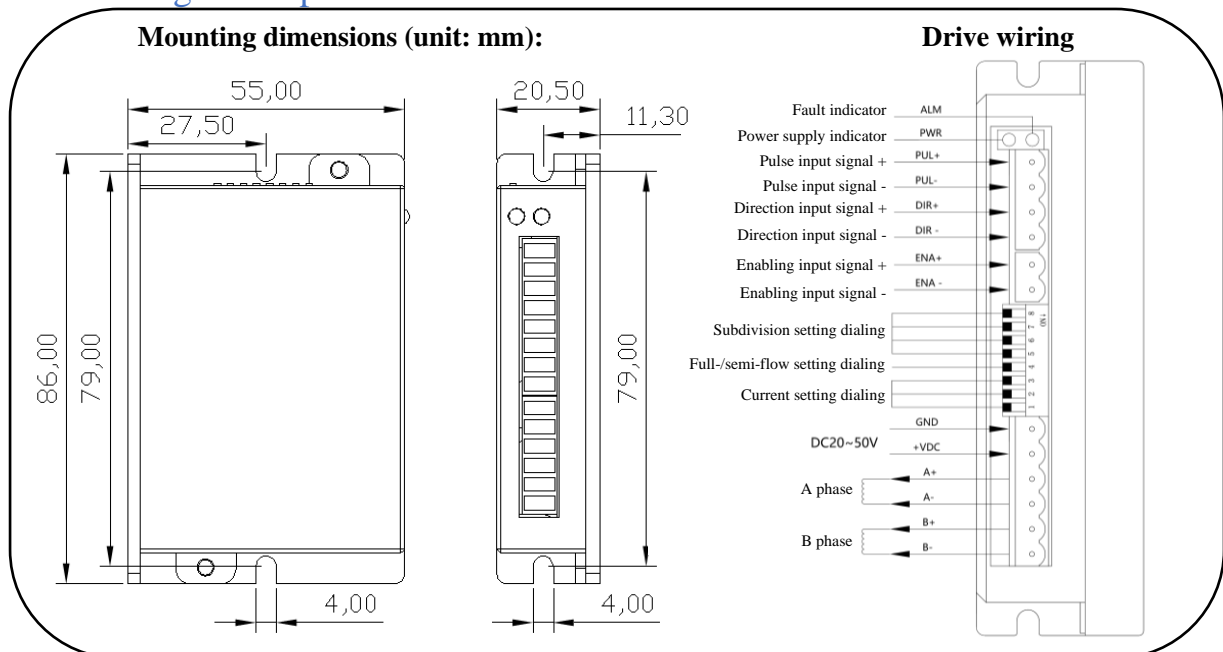

## Control signal wiring

- Differential signal input connection

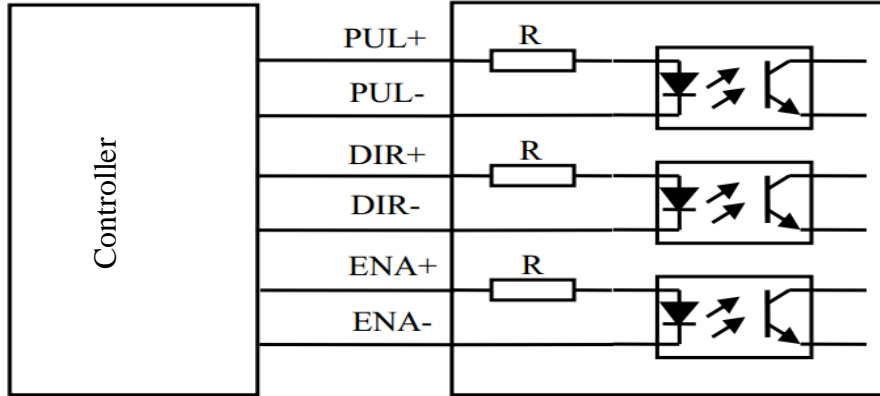

- Common anode connection

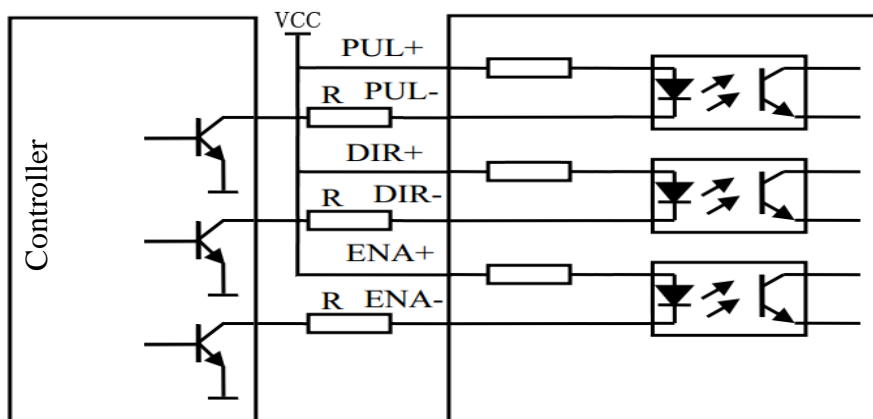

- Common cathode connection

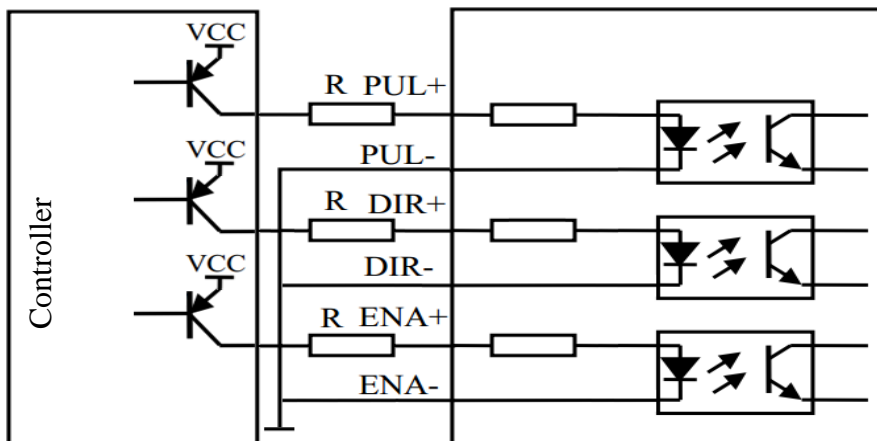

## Parameters setting

The subdivision accuracy, dynamic current and half-/full-current of the MC556-Min drive are set by an 8-bit dialing switch. The detailed description is as follows:

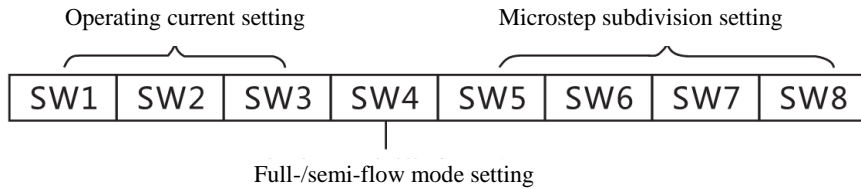

Automatic half-current function: When SW4 is dialed to OFF, the static current will be set to half of the dynamic current; When dialed to ON, the static current will be equal to the dynamic current;

It should be noted that generally SW4 should be set to OFF to reduce the temperature of the motor and drive and improve the reliability. After the pulse transmission stops for about 0.3s, the current can automatically decrease by 50% (55% actually), and the temperature can decrease by 65% theoretically.

### Operating current setting of MC556-Mini

Peak current (A)	Root-mean-square current (A)	SW1	SW2	SW3
1.4	1.0	OFF	OFF	OFF
2.1	1.5	ON	OFF	OFF
2.7	1.9	OFF	ON	OFF
3.2	2.3	ON	ON	OFF
3.8	2.7	OFF	OFF	ON
4.3	3.1	ON	OFF	ON
4.9	3.9	OFF	ON	ON
5.6	4.0	ON	ON	ON

### Microstep subdivision setting of MC556-Mini

Steps/revolution	SW5	SW6	SW7	SW8
Default	ON	ON	ON	ON
400	OFF	ON	ON	ON
800	ON	OFF	ON	ON
1600	OFF	OFF	ON	ON
3200	ON	ON	OFF	ON
6400	OFF	ON	OFF	ON
12800	ON	OFF	OFF	ON
25600	OFF	OFF	OFF	ON
1000	ON	ON	ON	OFF
2000	OFF	ON	ON	OFF
4000	ON	OFF	ON	OFF
5000	OFF	OFF	ON	OFF
8000	ON	ON	OFF	OFF
10000	OFF	ON	OFF	OFF
20000	ON	OFF	OFF	OFF
25000	OFF	OFF	OFF	OFF

## Driver function definition description

Drive function	Functions	Definition
POW	Power supply indicator	The green light is the power supply indicator, which will be normally On when the drive is powered on
ALM	Fault indicator	The red light is the fault indicator, which will be normally On in case of undervoltage, overvoltage and overcurrent
PUL+	Positive terminal of <b>pulse</b> control signal	Connect to a 5V power supply. It can be driven by a voltage withing +5V~24V. When the voltage is higher than 5V, current limiting resistors are needed; For +12V, a 1.2K $\Omega$ current limiting resistor is needed; For +24V, a 3K $\Omega$ current limiting resistor is needed.
PUL-	Negative terminal of <b>pulse</b> control signal	For controlling motor positioning. Effective at the low level. When the pulse changes from high to low, the motor runs one step, and the input resistance becomes 220 $\Omega$ ; Low level: 0~0.5V, pulse width: >2.5 $\mu$ s
DIR+	Positive terminal of <b>direction</b> control signal	Connect to a 5V power supply. It can be driven by a voltage withing +5V~24V. When the voltage is higher than 5V, current limiting resistors are needed; For +12V, a 1.2K $\Omega$ current limiting resistor is needed; For +24V, a 3K $\Omega$ current limiting resistor is needed.
DIR-	Negative terminal of <b>direction</b> control signal	For controlling motor rotation direction. Effective at the low level. Input resistance: 220 $\Omega$ ; Requirement: Low level: 0~0.5V, pulse width: >2.5 $\mu$ s
ENA+	Positive terminal of <b>enabling</b> control signal	Connect to a 5V power supply. It can be driven by a voltage withing +5V~24V. When the voltage is higher than 5V, current limiting resistors are needed; For +12V, a 1.2K $\Omega$ current limiting resistor is needed; For +24V, a 3K $\Omega$ current limiting resistor is needed.
ENA-	Negative terminal of <b>enabling</b> control signal	For switching off motor enabling after powering on (low level) to make motor axes be in a free state
GND	Negative pole of power supply	A DC power supply is used. Operating input voltage range: 20V~50VDC; Recommended operating voltage: 36VDC; Supply power: Over 100W
+VDC	Positive pole of power supply	
A+, A-	Motor power line	A+ and A - should be connected to the positive / negative terminals of the A-phase winding of the motor; B+ and B - should be connected to the positive / negative terminals of the B phase winding of the motor. When A - / B-phase windings are exchanged, the motor direction can be reversed.
B+, B-		

## Common fault and troubleshooting

Phenomenon	Possible problem	Solution
Motor not running	Power indicator not On	Use the power supply normally
	Too low set current	Select the appropriate current gear according to the rated current of the motor
	Drive protected	Power on again after troubleshooting
	Low enabling signal level	The signal is subject to a high level or not connected
	Control signal problem	Check the control signal for being normal
Incorrect motor rotation direction	Incorrect connection of motor power line	Exchange any two wires of the same phase of the motor (such as A+A_ connection position exchange)
	Open circuit of motor power line	Check the line for correct connection
Alarm indicator not On	Incorrect connection of motor power line	Check the wiring
	Too high voltage	Check the power supply voltage
	Motor or drive damaged	Replace the drive or motor
Inaccurate position	Signal interference	Remove the interference
	Shielding ground is not connected or loose	Ground reliably
	Subdivision error	Set subdivision correctly
	Low current	Increase the current appropriately
Motor stall during acceleration	Control signal problem	Check the control signal
	Too short acceleration time	Prolong the acceleration time appropriately
	Too low motor torque	Use a motor with higher torque
	Too low voltage or current	Set a higher voltage or current appropriately

- Note:**
1. Do not connect the power supply reversely;
  2. When the drive is powered on normally, the power indicator (green) PWR shall be On;
  3. When the fault indicator (red light) ALM is On, disconnect the power supply for inspection, and then power on again after troubleshooting.
  4. If power supply is higher than 5V, a resistor for current limiting should be connected;